

Code of practice

Fire extinguishing installations and equipment on premises

Part 1. Hydrant systems, hose reels and foam inlets
(Formerly CP 402.101)

Code de bonne pratique des installations et du matériel d'extinction de l'incendie dans les locaux

Partie 1. Systèmes de bornes d'incendie, dévidoirs et bouches de mousse

Richtlinien für Feuerlöschanlagen und -geräte in Gebäuden

Teil 1. Hydrantsysteme, Schlauchhaspeln und Schaumeinlaßöffnungen

Contents	Page	Section seven. Installation	Page
Foreword	1	27. Work on site	11
Code of practice		28. Protection of buildings under construction	11
0. Introduction	2	29. Temporary notices	11
Section one. General		Section eight. Initial inspections and acceptance tests	
1. Scope	2	30. Private underground fire hydrants	11
2. References	2	31. Tests on dry rising mains	11
3. Definitions	2	32. Tests on wet rising mains	12
Section two. Provision and siting of hydrants and risers		33. Hose reel tests	12
4. Fire hydrants, general	3	34. Foam inlet acceptance inspection	12
5. Fire hydrants, external	3	35. Indemnities	12
6. Rising mains	3	36. Test records	12
7. Landing valves	3	Section nine. Maintenance of systems and rectification of defects	
Section three. Design considerations for hydrants and risers		37. Fire hydrants	13
8. General	5	38. Rising mains	13
9. Water supplies and pumping arrangements	6	39. Hose reels	13
10. Identification of fire mains	7	40. Rectification of defects	13
11. Access for fire appliances	7	41. Hose reel accessibility	13
12. Electrical earthing	7	Figures	
13. Protection against frost	7	1. Typical layout of pit for underground fire hydrant (brick)	4
Section four. Hose reels		2. Typical layout of pit for underground fire hydrant (prefabricated)	4
14. General considerations	7	3. Typical installation for a hose reel	8
15. Provision and siting	7	4. Explanation of dimensions	9
16. Installation of hose reels	7	5. Co-ordinating spaces for fixed hose reels	9
17. Co-ordinating spaces for hose reels	8	6. Co-ordinating spaces for swinging arm or recess hose reels	9
18. Water supplies for hose reels	8	Appendices	
19. Hose reel notices	10	A. Recommendations for protecting installed equipment from theft and vandalism	14
Section five. Foam inlets		B. Matters to be considered relating to the provision of fire fighting installations during construction	14
20. General	10	This code of practice represents a standard of good practice and therefore takes the form of recommendations. Compliance with it does not confer immunity from relevant statutory and legal requirements.	
21. Capability of inlets and lines	10		
22. External connections	10		
23. Delivery pipe	10		
24. Termination of delivery pipe	10		
Section six. Components and materials			
25. General conformity with standards	10		
26. Particular requirements	10		



**Amendment No. 1
published and effective from 31 August 1984
to BS 5306 : Part 1 : 1976**

**Code of practice for fire extinguishing installations
and equipment on premises**

Part 1. Hydrant systems, hose reels and foam inlets

Revised text

AMD 4649
August 1984

Foreword

In paragraph 6, lines 3 and 4, delete 'Building Standard (Scotland) (Consolidation) Regulations 1971' and substitute 'Building Standards (Scotland) Regulations 1981 and 1982'.

AMD 4649
August 1984

Clause 6.1.1

Delete the existing clause and substitute the following.

'6.1.1 Rising mains should be installed in buildings where any floor is higher than 18 m (see note) above ground level. Where there are no floors higher than 60 m above ground level, wet or dry rising mains may be installed. Where there are floors higher than 60 m above ground level, wet rising mains are necessary owing to the pressures required to provide adequate water supplies at the landing valves at upper floors and also to ensure that water is immediately available at all floor levels.

NOTE. The Building Standards (Scotland) Regulations 1981 and 1982 specify 11 m in respect of buildings of occupancy sub-group A2 (Regulation E22 (1)(a)(i)).'

AMD 4649
August 1984

Clause 6.2.1

Insert the following sentence at the end of the clause.

'The position of inlets should be clearly indicated using the appropriate sign in accordance with BS 5499 : Part 1 and using a letter height of 50 mm.'

AMD 4649
August 1984

Clause 18.1 Minimum requirement

In line 5 delete '0.5 litre/s (30 litres/min)' and substitute '0.4 litre/s (24 litres/min)'.

Delete the last sentence and substitute the following.

'For example, when a length of 30 m of hose reel tubing (type A of BS 3169) is in use with a 6.5 mm nozzle, a minimum running pressure of 1.5 bar* will be required at the entry to each reel and similarly for a 4.5 mm nozzle where a minimum running pressure of 4 bar will be required.'

AMD 4649
August 1984

Figure 5. Co-ordinating spaces for fixed hose reels
Delete the existing drawing and substitute the following drawing.

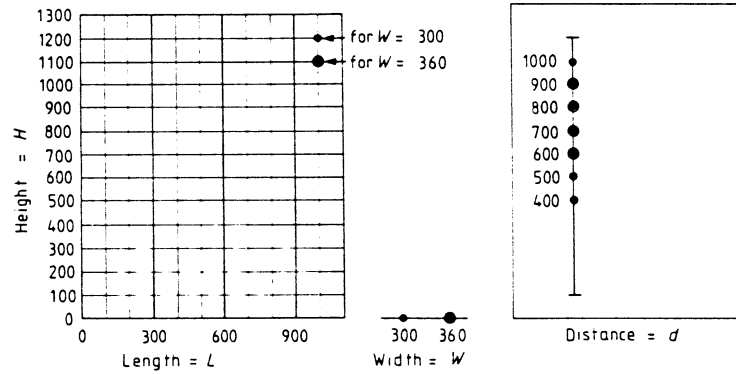

All dimensions are in millimetres.

Insert '(see also 14.2)' after the figure title.

AMD 4649
August 1984

Clause 19.3

Delete the existing clause and substitute the following.

'19.3 If hose reels are located in recesses to which doors are fitted, the doors (whether glazed or otherwise) should bear the appropriate sign in accordance with the requirements of BS 5499 : Part 1 but with a minimum letter height of 50 mm.'

AMD 4649
August 1984

Clause 22.1

In lines 5 and 6 delete 'must' and substitute 'should'.

Insert the following sentence at the end of the clause.

'The position of foam inlets should be clearly indicated using the appropriate sign in accordance with BS 5499 : Part 1 and using a letter height of 50 mm.'

AMD 4649
August 1984

Clause A.4.2

Delete the last sentence and substitute the following.

'The letters on this notice should preferably be in white and should be at least 50 mm high on a red background (see 40.2).'

AMD 4649
August 1984

Inside back cover

Insert the following reference in the list of publications referred to.

'BS 5499 Fire safety signs, notices and graphic symbols
Part 1 Specification for fire safety signs'



Amendment No. 2
published and effective from 29 February 1988
 to ~~BS 5306~~ : **Part 1** : 1976

Code of practice for fire extinguishing installations
and equipment on premises
Part 1. Hydrant systems, hose reels and foam inlets

Revised text

AMD 5756
 February 1988

Foreword (as amended by Amendment No. 1)

Delete paragraph 2 and substitute the following.

'The other Parts of BS 5306 are:

- Part 0 Guide for selection of installed systems and other fire extinguishing equipment
- Part 2 Sprinkler systems
- Part 3 Code of practice for selection, installation and maintenance of portable fire extinguishers
- Part 4 Specification for carbon dioxide systems
- Part 5 Halon systems
 - Section 5.1 Halon 1301 total flooding systems
 - Section 5.2 Halon 1211 total flooding systems
- Part 6* Foam systems
- Part 7* Powder systems '.

At the foot of the page insert the following associated footnote.

*In preparation.'

AMD 5756
 February 1988

New clause 7.3

After 7.2.4 insert the following.

'7.3 Notices. A notice reading either 'Dry riser' or 'Wet riser' as appropriate, should be displayed either on the door of the box or recess in which the landing valve is mounted, or in an adjacent prominent position if a door is not provided. The sign should be rectangular with white letters on a red background, in accordance with BS 5499 : Part 1. The letters should be lower case except for the initial letter 'D' or 'W', which should be upper case. The lower case letter height should be either not less than 50 mm, or of such smaller size only as may be necessary because of the size of the door.

NOTE. Boxes for dry risers complying with BS 5041 : Part 4 as amended by Amendment No. 1 (1986) are required to be marked as recommended in this clause.'

AMD 5756
February 1988

Clause 8.1.1

In paragraph 1, line 2, delete 'screwed and socketed,'.

After the first sentence insert the following.

'Pipework should be jointed by screwing and socketing, or by any other means selected as suitable for use, except at valves or other fittings where appropriate flanges in accordance with BS 4504 may be used. Such means may be selected on the basis of practical tests and evidence of satisfactory performance in similar applications such as wet or dry system sprinkler installations, for wet or dry risers respectively.'

At the end of the clause insert the following.

'NOTE. The Loss Prevention Council (LPC) publishes a list of components suitable for use in sprinkler installations.*'

At the foot of the page insert the associated footnote.

*Available from the Loss Prevention Council, 140 Aldersgate Street, London EC1A 4HY.'

AMD 5756
February 1988

Clause 8.1.3

At the end of the clause insert the following.

'Pipes should be made of one of the following:

- (a) steel in accordance with BS 1387;
- (b) copper in accordance with BS 2871 : Part 1, with fittings in accordance with BS 864 : Part 2;
- (c) plastics which are satisfactory to the water supply undertaking for this application, provided the pipework is protected from damage, by fire or otherwise, by location in a low risk area such as underground or in a service duct of brick, concrete or equivalent construction.'

AMD 5756
February 1988

Clause 8.3 Dry riser drain valves

Delete the second to last sentence and substitute the following.

'A notice reading 'Dry riser-drain valve' should be displayed in a prominent position adjacent to the valve. The lower case letter height should be not less than 25 mm. A notice, about 100 mm × 75 mm should also be displayed in the inlet box reading 'Low level drain valve in (here state location)'. The notices should be rectangular with white wording on a red background, and lower case except for the initial letter 'D' or 'L', which should be upper case, in accordance with BS 5499 : Part 1.'

AMD 5756
February 1988

New clause 9.4.5

After 9.4.4 insert the following.

'9.4.5 A notice reading 'Fire main pump motor supply — not to be switched off in the event of fire' should be displayed adjacent to all switches in the electrical power supply to pumps. The notice should be rectangular with white wording on a red background. The letter height should be not less than 25 mm and should be lower case except for the initial letter 'F', which should be upper case, in accordance with BS 5499 : Part 1.'

AMD 5756
February 1988

Clause 9.5.3

Delete the last sentence and substitute the following.
'A notice reading 'Fire main control valve' should be displayed adjacent to the valve. The notice should be rectangular with white wording on a red background. The letter height should be not less than 25 mm and should be lower case except for the initial letter 'F', which should be upper case, in accordance with BS 5499 : Part 1.'

AMD 5756
February 1988

Clause 18.1 Minimum requirement (as amended by Amendment No. 1)

Delete the clause and substitute the following.

'**18.1 Minimum requirement.** The water flow rate at the most hydraulically remote hose reel should be not less than 24 L/min, and the pressure sufficient to meet the range requirements of BS 5274, when it is in use simultaneously with the nearest adjacent hose reel.

NOTE. The method given in BS 5274 gives a test running pressure, at the reel inlet, of 4 bar* or 5 bar, for the maximum lengths of 25 mm and 19 mm hose respectively, with a requirement that the range of a jet be not less than 6 m. The range of a spray on a jet/spray nozzle may be less than this value.'

AMD 5756
February 1988

New clause 18.5

After 18.4 insert the following.

'**18.5 Security.** The main stop valve controlling the water supply to the hose reels should be secured fully open by a suitable device such as a padlocked chain or strap. Appropriate notices should be provided reading 'Fire hose reel main supply' (displayed at the stop valve controlling the water supply to the hose reels), and/or 'Fire hose reel pump motor supply – not to be switched off in the event of fire' (displayed adjacent to all switches in the electrical power supply to any pumps).

The notices should be rectangular with white wording on a red background. The letter height should be not less than 25 mm and should be lower case except for the initial letter 'F', which should be upper case, in accordance with BS 5499 : Part 1.

Notices should be resistant to weathering and to the effects of any industrial process in the vicinity.'

AMD 5756
February 1988

Clause 19. Hose reel notices (as amended by Amendment No. 1)

Delete the clause and substitute the following.

'Clause 19. Hose reel notices

NOTE. Hose reels complying with the requirements and recommendations of BS 5274 are required to be provided with notices which are in accordance with the recommendations of this clause.

19.1 A notice reading 'Fire hose reel' should be displayed adjacent to the hose reel (on the door if the hose reel is in a recess fitted with a door, glazed or otherwise). The notice should be rectangular with white wording on a red background. The letter height should be not less than 50 mm and lower case except for the initial letter 'F', which should be upper case, in accordance with BS 5499 : Part 1.

The notice should be resistant to weathering and the effects of any industrial process in the vicinity.

19.2 A notice giving full operational instructions should be displayed on or adjacent to the reel, whether this is manual or automatic. In the case of a manual hose reel in which an interlocking device is not incorporated the instructions should include the wording: 'Open valve before running out hose'.

NOTE. The interlocking device, where provided, ensures that the nozzle cannot be withdrawn until the water supply has been turned on.

The instructions should include specific instruction as to the correct method of closing the inlet valve to a manual fire hose reel, or of securing an automatic fire hose reel.

The notice should be in accordance with BS 5499 : Part 1, for fire equipment or supplementary signs.'

AMD 5756
February 1988

Clause 26. Particular requirements

In (h) delete '(in course of preparation)'.

In (k) delete 'BS 4312' and substitute 'BS 5160'.

In (p) delete 'to BS 1740' and substitute 'Wrought steel to BS 1740 or malleable iron to BS 143'.

In (q) delete 'BS 10 or'.

In (s) delete 'BS 1218' and substitute 'BS 5163'.

AMD 5756
February 1988

Clause 33.2 Procedure (direct mains supply)

In line 5, delete '9.3.1' and substitute '18.1'.

AMD 5756
February 1988

Inside back cover (as amended by Amendment No. 1)

In the list of BSI publications referred to in this standard, delete the entries for BS 10, BS 1218 and BS 4312, and also delete the asterisk against 'BS 5274'.

Insert the following in numerical order.

'BS 143 & 1256 Specification for malleable cast iron and cast copper alloy threaded pipe fittings
BS 864 Capillary and compression tube fittings of copper and copper alloy
Part 2 Specification for capillary and compression fittings for copper tubes
BS 2871 Specification for copper and copper alloys. Tubes
Part 1 Copper tubes for water, gas and sanitation
BS 5160 Specification for flanged steel globe valves, globe stop and check valves and lift type check valves for general purposes
BS 5163 Specification for predominantly key-operated cast iron gate valves for waterworks purposes
BS 5306 Fire extinguishing installations and equipment on premises
Part 0 Guide for selection of installed systems and other fire extinguishing equipment
Part 2 Sprinkler systems
Part 3 Code of practice for selection, installation and maintenance of portable fire extinguishers
Part 4 Specification for carbon dioxide systems
Part 5 Halon systems
Section 5.1 Halon 1301 total flooding systems
Section 5.2 Halon 1211 total flooding systems
Part 6* Foam systems
Part 7* Powder systems'

Foreword

This British Standard code of practice is a revision of CP 402.101: 1952 and as part of BSI's programme of metrication it is expressed in metric terms. For information on SI units reference should be made to BS 3763 'The International System of units (SI)'.

It comprises the first part of the BS 5306/CP 402 series of which the other parts in course of preparation are:

- BS 5306 Code of practice for fire extinguishing installations and equipment on premises
 - Part 2 Sprinkler systems (originally CP 402.201)
 - Part 3 Portable fire extinguishers for buildings and plant (originally CP 402 : Part 3)
 - Part 4 Foam, inert gas and dry powder systems

The revision has been made in the light of current progress in revising the CP 3:Chapter IV series, Code of basic data for the design of buildings: 'precautions against fire', and in conjunction with the preparation of the new range of standards covering particular items of equipment for fixed fire fighting installations in buildings. Some of the information previously found in this code is now to be published in these new standards, notably that on hose reels (BS 5274 in course of preparation).

Since CP 402.101: 1952 was prepared the practice of stowing long lengths of hose adjacent to landing valves has fallen out of favour, and this aspect of the subject has therefore been omitted from the revised code. It is nowadays the practice for hose to be brought to the site by the fire brigade.

It is recognized that recent projects such as shopping malls and town centre development and redevelopment schemes may be inaccessible to conventional fire appliances and may require special measures such as horizontal mains, but this code of practice does not give guidance on these special measures. Reference should be made to Fire Prevention Guide No. 1 'Fire precautions in town centre development' (published by HMSO). The fire authority should also be consulted.

In England and Wales, the provision of hydrant systems is largely a matter of voluntary good practice. In Scotland these are mandatory requirements in the Building Standards (Scotland) Regulations, 1981 and 1982, and amendments thereof or additions thereto relating to the provision of fire mains do not necessarily coincide with the requirements of this code of practice.

Fire extinguishing installations and equipment on premises

Part 1. Hydrant systems, hose reels and foam inlets

0. Introduction

It is important that the fire protection of a building should be considered as a whole. Hydrant systems, hose reels and foam inlets form only part, although an important part, of such facilities and it should not be assumed their provision entirely obviates the need for portable fire extinguishers, other appliances or other fixed fire suppression systems. Wet and dry rising mains are intended for use by fire brigade or other trained personnel and provide a readily available means of delivering considerable quantities of water to extinguish or to prevent the spread of fire. Hose reels, although delivering smaller quantities of water, are capable of operation by untrained persons who may be in the vicinity when the fire is discovered, and thus can be more rapidly brought into action to tackle a fire in its early stage of development. They may also be required for use by the fire brigade on arrival at the scene. They provide a continuous and easily controlled water jet and thus are generally more effective than portable fire extinguishers and less damaging than larger jets. Foam inlets have a more specialized role in dealing with oil fires and with fires involving electrical apparatus where a quantity of oil is involved.

It should not be assumed that the provision of efficient hydrant systems and hose reels entirely obviates the need for portable fire extinguishers and other hand appliances. On the contrary, these items may provide the best means of rapidly extinguishing a small fire before it has taken hold and before even a hose reel can be brought into action. Therefore consideration should always be given to supplementing hydrant systems and hose reels with hand appliances. Moreover portable fire extinguishers may be required for certain special risks. Advice on such matters can always be obtained from the fire authorities, H.M. Factory Inspectorate and the fire insurance companies. In addition, reference should be made as necessary to other parts of this code of practice.

It is essential that fire extinguishing equipment should be carefully maintained to ensure instant readiness when required. This routine is frequently tedious and liable to be overlooked or given insufficient attention by supervisors. It is however neglected at peril to the lives of occupants of the premises and at the risk of crippling financial loss. Its importance cannot be too highly emphasized.

Section one. General

1. Scope

This code of practice covers good practice in matters affecting the planning, installation, testing and upkeep of fire hydrant systems including wet and dry rising mains, hose reels and foam inlets on premises.

Although statutory fire hydrants need to be considered when co-ordinating all fire fighting systems in a locality, the scope of this code of practice does not include them and if information is required concerning them reference should be made to the fire authority.

2. References

The titles of the British Standards publications referred to in this standard are listed on the inside back cover.

3. Definitions

For the purposes of this standard the following definitions apply. They are the same as the terms adopted for general use in BS 4422: Part 4 except that certain additional definitions have been included. These additional definitions are marked with an asterisk.

3.1 coupling*. A device for connecting lengths of hose so as to secure continuity from the source of a water supply to the delivery point.

3.2 fire hydrant (underground fire hydrant). An assembly contained in a pit or box below ground level and comprising a valve and outlet connection from a water supply main.

3.3 fire hydrant, pillar. A fire hydrant whose outlet connection is fitted to a vertical component projecting above ground level.

3.4 foam inlet. Fixed equipment consisting of an inlet connection, fixed piping and a discharge assembly, enabling firemen to introduce foam into an enclosed compartment.

3.5 hydrant outlet. The component of fire hydrant to which the standpipe is connected.

3.6 hose reel. Fire fighting equipment, consisting of a length of tubing fitted with a shut-off nozzle and attached to a reel, with a permanent connection to a pressurized water supply.

3.7 landing valve. An assembly comprising a valve and outlet connection from a wet or dry riser.

3.8 ring fire main system*. A water main which encircles a building or series of buildings or other associated fire risks and which feeds fire hydrants, internal rising mains etc.

3.9 rising main, dry (dry riser). A vertical pipe installed in a building for fire fighting purposes, fitted with inlet connections at fire brigade access level and landing valves at specified points, which is normally dry but is capable of being charged with water usually by pumping from fire service appliances.

3.10 rising main, wet (wet riser). A vertical pipe installed in a building for fire fighting purposes and permanently charged with water from a pressurized supply, and fitted with landing valves at specified points.

3.11 shut-off nozzle*. A device which is coupled to the outlet end of hose reel tubing and by means of which the jet of water or spray is controlled.

Section two. Provision and siting of hydrants and risers

4. Fire hydrants, general

4.1 When they are considered to be necessary, private fire hydrants should be provided within the confines of the site after consultation with the local water and fire authorities. Their installation should conform generally to this code of practice and also to any specific requirements of these authorities or the insurance company.

4.2 Fire hydrants should be positioned in such a way that the parking, loading and unloading of vehicles is unlikely to obstruct them, and in choosing locations for them regard should be paid to the availability of statutory hydrants in public thoroughfares nearby.

5. Fire hydrants, external

5.1 Where fire hydrants are to be installed, they should be included as part of a ring fire main system (see 9.7) and be positioned not more than 70 m from an entry to any building on the site and not more than 150 m apart. They should preferably be sited immediately adjacent to roadways or hard-standing facilities provided for fire brigade appliances. They should normally be not less than 6 m from the building or from the risk so that they remain usable during a fire.

5.2 For underground fire hydrants which unavoidably have to be sited in roadways care should be taken that the surface box frame and cover (which should be in accordance with BS 750) are capable of bearing the heaviest vehicle which may use the roadway.

5.3 Underground fire hydrants should be in accordance with BS 750 and be installed in pits, examples of which are shown in figures 1 and 2. Each fire hydrant should be clearly indicated by a plate in accordance with BS 3251 affixed nearby in a conspicuous position. The preferred distance, when installed, between the hydrant outlet and the finished ground level is 300 mm.

5.4 Where pillar hydrants are installed care should be taken to protect them from mechanical damage and from damage by frost.

6. Rising mains

6.1 General

6.1.1 Rising mains should be installed in buildings where any floor is higher than 18 m (see note) above ground level. Where there are no floors higher than 60 m above ground level, wet or dry rising mains may be installed. Where there are floors higher than 60 m above ground level, wet rising mains are necessary owing to the pressures required to provide adequate water supplies at the landing valves at upper floors and also to ensure that water is immediately available at all floor levels.

NOTE. The Building Standards (Scotland) Regulations 1981 and 1982 specify 11 m in respect of buildings of occupancy sub-group A2 (Regulation E22 (1)(a)(i)).

6.1.2 Each rising main should be provided with landing valves sited:

- (a) within a ventilated lobby of a lobby approach stairway, where this is provided, or
- (b) in a stairway enclosure, or
- (c) in such other position as may be agreed with the fire authority.

6.1.3 In some cases a simple single cable and plug telephone system may be recommended by the fire authority to assist communication between the ground floor and the floor at which a landing valve is in use.

6.2 Position of inlets

6.2.1 In selecting positions for inlet connections for a dry rising main, regard should be paid to the positions of underground fire hydrants, the possibility of damage resulting from falling glass from windows and other possible occurrences during a fire. The position of inlets should be clearly indicated using the appropriate sign in accordance with BS 5499 : Part 1 and using a letter height of 50 mm.

6.2.2 Inlet connections for a dry rising main should be installed in an external wall or in a boundary wall of a building as close as possible to the position of the main which they serve, and any run of connecting pipe between the inlet and the vertical run of the main should be kept to a minimum and should be given a fall towards the drain valve. Access to these inlet connections should be in accordance with clause 11.

6.3 Number of rising mains. The number and disposition of rising mains normally should be such that:

- (a) one is provided for every 900 m², or any part thereof, of the floor area at each level other than the ground floor;
- (b) rising mains are not more than 60 m apart in a horizontal direction;
- (c) no part of a floor area is more than 60 m distant from a landing valve: the distance to be measured along a route suitable for hose lines, including any distance up or down a stairway.

7. Landing valves

7.1 Provision of landing valves

7.1.1 Landing valves should be provided inside the building on wet or dry rising mains at each level above the ground floor, and on dry mains, if practicable, at roof

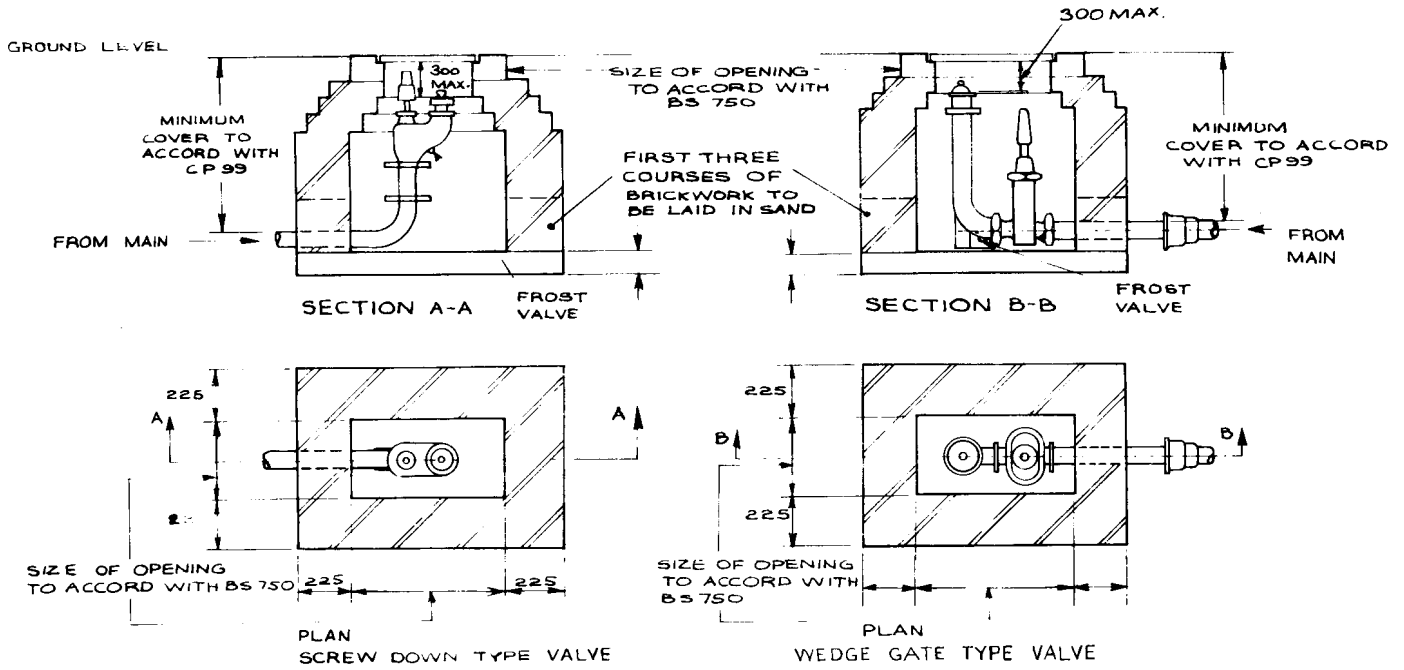

All dimensions are in millimetres

Figure 1. Typical layout of pit for underground fire hydrant (brick)

Surface box to BS 750

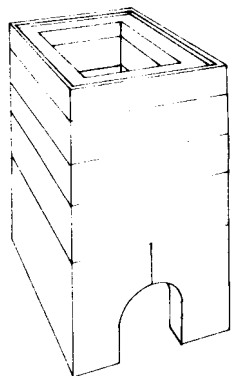
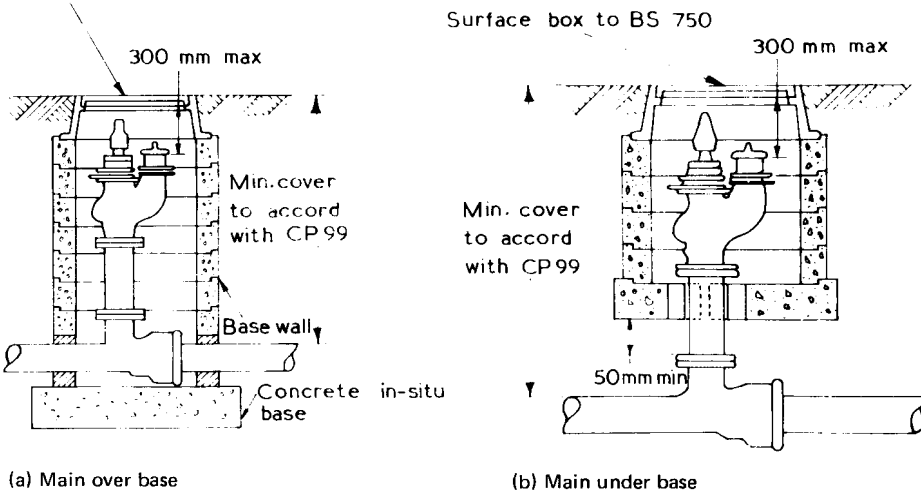

Prefabricated sections as assembled

NOTE. (1) All sections interlock with dry joints.
 (2) Number of precast sections to suit depth of main.

Figure 2. Typical layout of pit for underground fire hydrant (prefabricated)

level for test purposes. For tests on wet mains see 32.1. In buildings with basements of unusual depth or extent it may be advisable to extend the installation and provide landing valves at lower levels.

7.1.2 Landing valves are desirable on every floor above the ground floor in blocks of flats, and on every entrance floor above the ground floor of the block in blocks of maisonettes.

7.1.3 Landing valves should be protected against interference and attack by thieves and vandals as far as it is possible to do so without adversely affecting operational capability. Recommendations for effecting this are given in appendix A.

7.1.4 Normally one landing valve is provided at each level on each riser, but if, owing to the degree of fire risk, it is necessary to install two, the normal size of the riser should be increased in accordance with 8.1.2.

7.1.5 Landing valves for dry rising mains should comply with the requirements of BS 5041 : Part 2 and those for wet rising mains should comply with the requirements of BS 5041 : Part 1.

7.2 Recesses and enclosures for landing valves

7.2.1 In all cases a landing valve should be installed with its lowest point about 750 mm above floor level.

7.2.2 Landing valves for dry rising mains should preferably be protected by, and installed within, a box in accordance with BS 5041 : Part 4.

Landing valves for wet rising mains may also be protected by boxes when special circumstances exist. Some types of these valves can be fitted in boxes complying with the requirements of BS 5041 : Part 4 and still leave the clearances required by that standard: in such cases a box complying with the requirements of BS 5041 : Part 4 should be used. The majority of these valves however cannot be accommodated in standard boxes and, in these cases, special boxes should be designed to ensure that the clearances recommended in 7.2.3 are assured.

7.2.3 When a landing valve for a wet rising main is enclosed in a box, and when any valve is unenclosed in an open recess, or is located in a duct or alcove, the opening giving access to the landing valve should have not less than 150 mm clearance on both sides and not less than 230 mm below the centre line of the outlet of the landing valve and not less than 200 mm clearance above the handwheel. The depth of the opening should not be greater than is necessary, and in no case should the front edge of the female coupling of the landing valve be more than 75 mm behind the face of the wall. In addition, consideration should be given to allowing adequate space around the valve to permit maintenance and testing.

7.2.4 If enclosure of the valve in a box is not desired or is impracticable owing to the main and the landing valves not being in a duct or alcove, each landing valve on a dry rising main should be strapped shut, the strap being secured by a locked padlock. If it is required that the landing valve be enclosed in a manner otherwise than in accordance with BS 5041 : Part 4, details of the proposal should be discussed with the fire authority before any work is put in hand.

Section three. Design considerations for hydrants and risers

8. General

8.1 Rising mains

8.1.1 Rising mains and associated pipework should be of wrought steel pipe, heavy quality, screwed and socketed, and the fittings should be of wrought steel. Pipework for dry risers and fittings for both wet and dry risers should be galvanized (see clause 26). All changes in the direction of the run of the piping should be made with standard bends, springs or long turn fittings. Elbows should not be used.

The whole of the installation, including all valves and fittings, should be satisfactory to the water undertaking. Before any work starts, plans showing details of the arrangements proposed should be submitted to the undertaking and to the fire authority and their approval obtained thereto.

8.1.2 Wet or dry rising mains should have a nominal bore of 100 mm where only one outlet is provided on each floor level on each riser. If two outlets are permitted on any level on any one riser the main should have a nominal bore of 150 mm.

8.1.3 Rising mains and associated pipework for hydraulic hose reels should not normally be less than 50 mm nominal bore and feeds to individual hose reels should be not less than 25 mm nominal bore. Exceptionally, where the water pressure is adequate at all times to satisfy the requirements of 9.2, the size of rising mains and ring mains may be reduced, but in no case should any individual pipe be less than 25 mm nominal bore.

8.1.4 The design and installation of hydrant systems should be closely correlated with all other services being provided in the building, and ducts may be shared. However, except as stated below, the water supply to hydrants and hose reels should be kept entirely independent from other water supplies including those for other fire fighting systems. In certain special circumstances the supply to hose reels may be taken from the supply provided for a sprinkler system (see CP 402.201 and the Fire Offices' Committee (FOC) 'Rules for automatic sprinkler installations').

8.2 Dry riser inlets. A 100 mm dry rising main should be fitted with a two-way inlet breeching and a 150 mm dry rising main should be fitted with a four-way inlet breeching. Each breeching should comply with the requirements of BS 5041 : Part 3. Such breeching should be accommodated in an inlet box complying with the requirements of BS 5041 : Part 5, the box being positioned with its lower edge between 400 mm and 600 mm above ground level.

8.3 Dry riser drain valves. BS 5041 : Part 3 relating to inlet breechings provides that each breeching should be fitted with a 25 mm drain valve to facilitate draining the rising main after use. If any part of the pipework of the rising main falls below inlet box level an additional drain valve should be provided at the lowest point of the pipework, together with either fixed piping or an adequate length of flexible tubing (fitted with a suitable coupling

for connection to the valve) to conduct water from the valve to a suitable drain. Where such a low level drain valve is fitted a permanent notice should be provided in 25 mm (minimum) block letters of a suitable colour on a contrasting background and placed in a position adjacent to the valve reading 'DRY RISER – DRAIN VALVE', and a further permanent notice should be provided in the inlet box, similar in size to the indicator plates mentioned in BS 5041 : Part 5, reading 'LOW LEVEL DRAIN VALVE IN (here state location of the valve)'. The low level drain valve should be kept strapped and padlocked closed except when in use.

9. Water supplies and pumping arrangements

9.1 Means of supply

9.1.1 For wet rising mains and hose reels it is essential that pressures and flows should at all times be adequate to serve the designed number of jets likely to be used. This is irrespective of the source of water supply.

9.1.2 However, for dry rising mains a high pressure supply is not essential as the pressure can be controlled by fire brigade pumps. Dry rising mains can be supplied from static or open water supplies, although it is normal in built-up areas to rely upon town's water.

9.1.3 External underground hydrants usually depend on supplies available from town's mains.

9.2 Adequacy of basic supply. In all cases where town's main supply is involved, the capacity of the mains is important and should be checked. Generally a water supply capable of providing a minimum of 25 litre/s (1500 litre/min) at all times will be required (see 9.3.1).

9.3 Supplementing the basic supply for wet rising mains

9.3.1 In many cases the town's main supply may not provide sufficient pressure to provide the supply necessary at upper floors on a high building. In such cases each rising main should be fed from a suction tank or inter-connected tanks having a minimum capacity of 45 000 litres. The tank or tanks should be automatically supplied from a town's main(s) controlled by ballvalve(s) and the capacity of these mains together with the contents of the tank(s) should be such as to maintain a flow of water capable of supplying three fire-fighting jets for 45 min when water is being used at a total rate of 25 litres/s (1500 litres/min). If buildings exceed a height of 120 m the provision of additional storage capacity should be considered.

9.3.2 Tanks supplying water for domestic purposes should not be used as suction tanks for wet rising mains unless arrangements have been made for these domestic supplies to be drawn off in such a manner that the requisite reserve of water for the rising main is always preserved.

9.4 Pumps for wet rising mains

9.4.1 Two automatic pumps should be installed to feed the wet rising main, one of which should act as standby, each pump being supplied by a different source of power, e.g. electricity or diesel engine, and arranged so that when acting as duty pump it will operate automatically, i.e. on a flow of water or a fall in pressure on the installation. The secondary pump should be so arranged that it will operate automatically on a failure for any reason of the duty pump. Both pumps should be primed automatically at all times. This will be effected if the

pumps are sited so that at least two thirds of the effective capacity of the suction tank is above the level of the top of the pump casings. Where this is not possible, separate priming tanks and foot valves should be provided for each pump.

9.4.2 All pumps should also be capable of being started and stopped manually.

9.4.3 An audible and visual alarm should be provided at an agreed position to indicate that the equipment and the pumping plant have operated.

9.4.4 Each pump should be capable of providing a flow of water of at least 25 litre/s (1500 litres/min) in the wet rising main, i.e. sufficient to serve three lines of hose from three landing valves simultaneously. A minimum running pressure of 4 bar* and a maximum of 5 bar should be maintained at each landing valve when any number, up to three, are fully opened.

9.5 Additional precautions for wet rising mains

9.5.1 Arrangements for draining a wet rising main should be incorporated to enable any necessary repairs to be carried out.

9.5.2 To reduce the risk of hose bursting, arrangements should be made in accordance with BS 5041: Part 1 so that when the water is shut off at the nozzle the static pressure in any line of hose connected to a landing valve does not exceed 7 bar.

To dispose of excess flows and pressures over and above those required (i.e. when only one jet is in use) a pressure control valve should be incorporated in the body of the landing valve which is then permanently connected into the relief pipe. This relief pipe should run throughout the length of the wet rising main installation and should terminate, as required by the water undertaking, either back into the suction tank or to waste.

9.5.3 Where a rising main is supplied direct from a town's main supply and a shut-off valve is incorporated in the rising main the valve should be kept secured in the open position by a chain and padlock. In addition a notice reading 'FIRE MAIN CONTROL VALVE' in letters at least 25 mm high should be displayed adjacently.

9.5.4 Where a rising main is bifurcated, valves should be provided to enable either branch to be isolated for repair without adversely affecting the other one.

9.6 Emergency arrangements for filling suction tanks. It must be envisaged that conditions can arise when the pre-arranged methods of filling the suction tanks may be out of action due to circumstances beyond the control of the building occupiers or owners. It is therefore recommended that where the tanks are no higher than 60 m above ground level, pipes of not less than 100 mm nominal size be installed having an open end at a convenient distance above the maximum level of the water in the tank(s) and their other ends connected to an appropriately sized inlet breeching provided in an inlet box at a convenient position on the face of the building (see 22.1 and 8.2). By these means the fire brigade would be able to keep the tanks replenished in the event of an emergency and so provide the minimum amount of water necessary (see 9.3.1). The water authority should be consulted in this connection.

9.7 Ring main supply. Where a number of underground fire hydrants or wet rising mains are required because of

*1 bar = 10^5 N/m² = 100 kPa

the area of the premises to be covered, the mains supplying these fire hydrants should be in the form of a ring main to form a complete circuit of the site. It is advisable for water to be supplied to the ring at more than one position, preferably from supplies obtained from different mains. Isolating valves complying with the requirements of BS 1218 should be incorporated in the system so that sections of the ring main can be isolated to enable repairs to be carried out. Branches to town's mains should also have an isolating valve and a non-return valve to suit the water undertaking's requirement.

10. Identification of fire mains

Where it is necessary to identify fire mains and associated equipment they should be identified in accordance with BS 1710.

11. Access for fire appliances

11.1 Buildings fitted with dry rising mains or foam inlets. Buildings fitted with dry rising mains or foam inlets, or both, should have access roads for fire appliances to within 18 m of the inlet connections, within sight of them and with unrestricted access thereto.

11.2 Buildings fitted with wet rising mains

11.2.1 Buildings fitted with wet rising mains should have access roads to within 18 m of the ground floor access point of the stairway enclosure in which each wet rising main is situated, or if the main is not situated in a stairway enclosure, to within 18 m of the foot of the nearest enclosed stairway to the main. The road should be within sight of the building and there should be unrestricted access across the intervening space.

11.2.2 If emergency arrangements for filling suction tanks as described in 9.6 are installed in a building, any access roads should be extended to within 18 m of the inlet to the pipework for those emergency arrangements and with unrestricted access thereto.

11.3 Access road specification. Access roads may be common highways, private roads, footpaths or specially strengthened and defined routes through the surrounding terrain and should have a minimum width of 3.6 m and be capable of carrying a pumping appliance with a 'laden weight' of 12 tonnes. Any bends in access roads should be able to accommodate an appliance having a minimum turning circle of 17 m diameter. Minimum clearance height should be 3.6 m and any gates should have a width of 3 m in the clear and be openable from either side. Unless adequate turning facilities already exist a suitable means to enable fire appliances to turn round should be provided.

NOTE. The recommendations given in 11.3 relate to the needs of access for pumping appliances used for charging dry risers or for pumping into foam inlets. However, when fire breaks out the fire brigade may wish to send other larger and heavier appliances (e.g. hydraulic platforms) which need stronger roads and wider operational space. The fire authority should in all cases be consulted before access road specifications are settled.

12. Electrical earthing (see also CP 1013)

12.1 Dry rising mains should be electrically earthed. Those joints which do not provide electrical continuity should be bonded.

12.2 A foam inlet delivery pipe in a transformer chamber should also be electrically earthed. (see clause 24).

13. Protection against frost

13.1 Hydrant systems should be afforded all possible protection against frost. (See CP 99.) Wet rising mains should not be located against or near external walls unless they are adequately insulated or otherwise satisfactorily protected.

Section four. Hose reels

14. General considerations

14.1 Conformity to standard. Hose reels should comply with the requirements of BS 5274.

14.2 Limitation of hose in certain circumstances.

Although BS 5274 permits up to 45 m of hose on hose reels, frequently there are circumstances in which there is a likelihood of the hose having to be handled by persons of only moderate physical strength. In such cases, and also when the likely routes for the hose are tortuous, the length and size of hose on the reel should be limited, and the siting and provision of reels should be reviewed with these limitations in mind.

15. Provision and siting

15.1 Provision. One hose reel should be provided to cover every 800 m² of floor space or part thereof.

15.2 Siting

15.2.1 Hose reels should be sited in prominent and accessible positions at each floor level adjacent to exits in corridors on exit routes, in such a way that the nozzle of the hose can be taken into every room and within 6 m of each part of a room, having regard to any obstruction. Where heavy furniture or equipment may be introduced into a room, the hose and nozzle should be capable additionally of directing a jet into the back of any recess formed.

15.2.2 In exceptional circumstances consideration may also be needed as to the desirability of siting hose reels in such a way that if a fire prevents access to one hose reel site, the fire can be attacked from another hose reel in the vicinity.

16. Installation of hose reels

16.1 Hose reels in recesses. Preferably hose reels should be installed in recesses so that they do not form obstructions on a route of escape. The details of installation will vary considerably owing to the wide variation of types of hose reel and their size. A typical example of an installation of a fixed hose reel is illustrated in figure 3.

16.2 Recess doors. Any doors provided for hose reel recesses should be so hinged that they open approximately 180° so as not to offer any obstruction to the hose being run out in either direction. The doors should not normally be fitted with locks.

16.3 Hose reels in open areas. When installed on open floor areas it may be necessary to position hose reels above head height, but in these cases the nozzle retainer, the hose guide and the inlet valve should be fitted at about 900 mm above floor level. It may also be desirable to provide an anti-over-run device to prevent the hose from becoming entangled when run out.

16.4 Importance of firm fixing. Hose reel brackets should be firmly fixed to the wall so that casual knocks received during normal use of the building and the stresses incurred during use for firefighting will not prevent the unimpeded use of the hose reel.

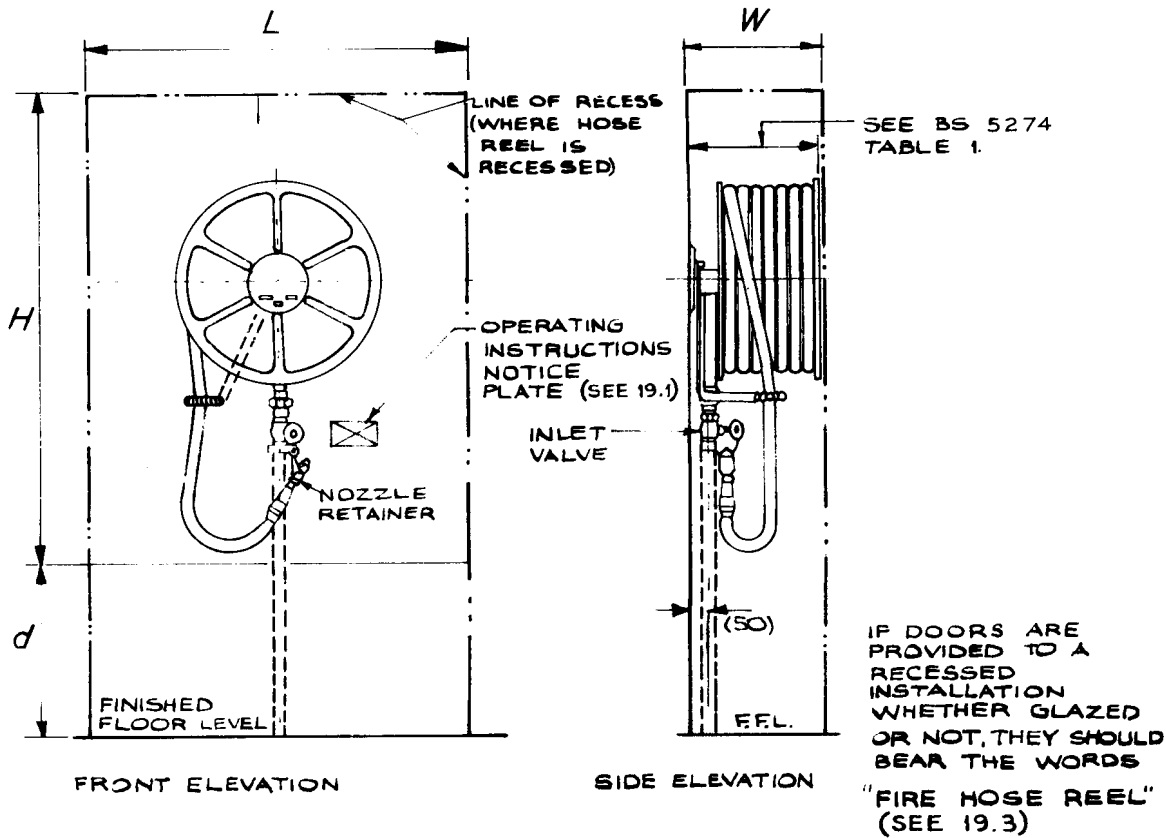

NOTE 1. Hose reel conforming to BS 5274.
 NOTE 2. For sizes of spaces and height above floor level see clause 17.

Figure 3. Typical installation for a hose reel

17. Co-ordinating spaces for hose reels

17.1 The spaces required for most types of hose reel and recommendations concerning their location in relation to floor or ground level are indicated in figures 3, 4 and 5. Spaces for 'horizontal' hose reels are not given as these are considered to be special installations.

17.2 The definitions of the different types of hose reel and the maximum overall size of each type are given in BS 5274.

17.3 The figures (according with those given in PD 6444 : Part 3) indicate the range of acceptable choices from the point of view of dimensional co-ordination. First preferences are indicated by a thick blob and second preferences are indicated by a smaller blob.

NOTE 1. The basic space accommodates:

- (a) the reel and valve;
- (b) the hanging loop of hose;
- (c) the guide or necessary space for proper withdrawal of the hose;
- (d) the component case (if any).

NOTE 2. The space sizes have been based on the normal arrangement where the water supply is fed upwards. Downwards or sideways feeds should be treated as special installations.

18. Water supply for hose reels (see also 8.1.4)

18.1 Minimum requirement. As a minimum, the water supply to hose reels should be such that when the two top-most reels in a building are in use simultaneously, each will provide a jet of approximately 6 m in length and will

deliver not less than 0.4 litre/s (24 litres/min). For example, when a length of 30 m of hose reel tubing (type A of BS 3169) is in use with a 6.5 mm nozzle, a minimum running pressure of 1.5 bar* will be required at the entry to each reel and similarly for a 4.5 mm nozzle where a minimum running pressure of 4 bar will be required.

18.2 Booster pumps

18.2.1 Where the water pressure in hose reel mains needs to be boosted, the provision of an electrically driven pump is usually a convenient method. A duplicate standby pump should also be provided.

18.2.2 Both motors and pumps should be sited in fire protected positions and the electrical supply to them should be by an exclusive circuit with the cables following a route of negligible fire risk or be provided with adequate protection.

18.2.3 The booster pumps system should come into operation automatically on a drop in pressure or a flow of water. Both pumps should be automatically primed at all times (see 9.4.1).

18.2.4 All pumps should also be capable of being started or stopped manually. The standby pump should be so arranged that it will operate automatically on a failure for any reason of the duty pump

18.2.5 An audible and visual alarm should be provided at an agreed position to indicate that the equipment and the pumping plant have operated.

18.3 Connection for boosted supplies. Some water undertakings do not permit a booster pump to be connected

*1 bar = $10^5 \text{ N/m}^2 = 100 \text{ kPa}$

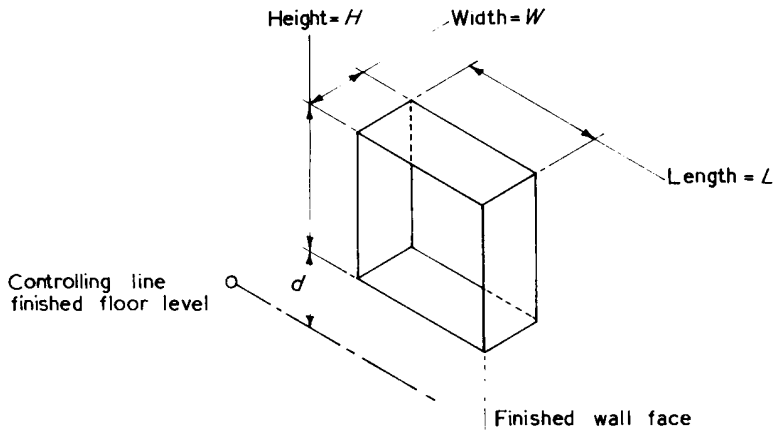
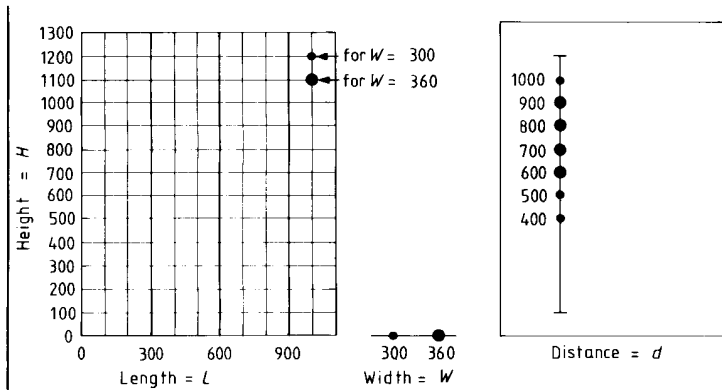
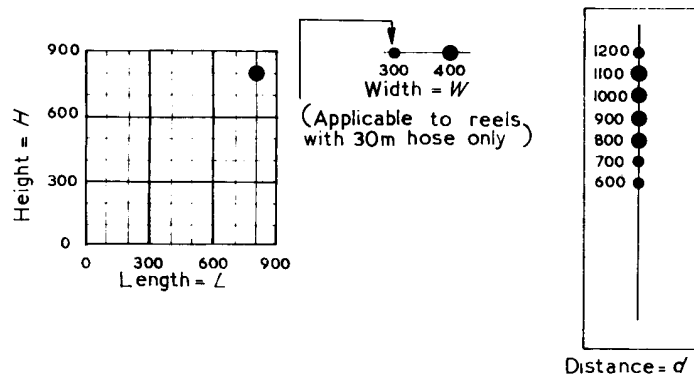

Figure 4. Explanation of dimensions (for further details see figure 3)



All dimensions are in millimetres

Figure 5. Co-ordinating spaces for fixed hose reels (see also 14.2)



All dimensions are in millimetres

Figure 6. Co-ordinating spaces for swinging arm or recess type hose reels

directly into a supply main. In such cases the installation should be fed from a suction tank or inter-connected tanks having a minimum capacity of 1125 litres. The tank or tanks should be automatically supplied from a towns main, controlled by a ball valve of minimum diameter 50 mm.

18.4 Use of domestic water tanks. Tanks supplying water for domestic purposes should not be used as suction tanks for hose reel installations unless arrangements have been made for these domestic supplies to be drawn off in such a manner that the requisite reserve of water for the hose reel installation is always preserved.

19. Hose reel notices

19.1 For hose reels which do not have automatic action a notice should be provided indicating the need to turn on the inlet valve before running out the hose. This notice should be affixed to the wall in a prominent position adjacent to the reel. (See figure 3.)

19.2 All notices should be set out in letters easily readable in adverse conditions. They should be made so that they are not unreasonably affected by weathering or by corrosion caused by industrial processes in the vicinity.

19.3 If hose reels are located in recesses to which doors are fitted, the doors (whether glazed or otherwise) should bear the appropriate sign in accordance with the requirements of BS 5499 : Part 1 but with a minimum letter height of 50 mm.

Section five. Foam inlets

20. General

Oil risks situated at or below ground level, e.g. oil-fired boiler rooms oil storage tank chambers or transformer chambers, where they may not be directly accessible for fire-fighting operations, may require foam inlets so that foam can be applied to a fire from outside a building by means of a system of fixed piping and suitable outlets. The fire authority should be consulted on this matter.

21. Capability of inlets and lines

Not more than three outlets, having an aggregate cross-sectional area of not more than 3200 mm² should be supplied by one inlet and one line of delivery pipe. Where there are more than three outlets, or the aggregate cross-sectional area of the outlets appreciably exceeds 3200 mm², additional inlet(s) and delivery pipe(s) should be installed.

22. External connections

22.1 The external connection should normally be housed in a box conforming with BS 5041 : Part 5 built into an external wall of a building, or into a boundary wall so that the bottom of the box is at a level between 300 mm and 600 mm above the ground. There should be at least 2.50 m of clear working space in front of the box, and it should be clear of openings from the space protected, so that the foam inlet may be used without undue exposure of personnel to heat and smoke. Access to these connections should also conform to the requirements given in clause 11.

The position of foam inlets should be clearly indicated using the appropriate sign in accordance with BS 5499 : Part 1 and using a letter height of 50 mm.

22.2 Depending upon local requirements, the external connection fitted in the inlet box (see 22.1) should be:

- either (a) an instantaneous male coupling complying with the requirements of BS 336
- or (b) a foam inlet adaptor complying with the requirements of BS 336.

23. Delivery pipe

23.1 The delivery pipe from each foam inlet to the space protected should not exceed 18 m in total length and should be 65 mm or 80 mm nominal bore galvanized wrought steel pipe, screwed and socketed. The run of pipe should be as direct as possible with a fall away from the inlet provided on all sections of it, and any changes of direction should be made with standard bends, springs or long turn fittings; elbows should not be used. The pipe from one inlet should serve only one space.

24. Termination of delivery pipe

Normally the delivery pipe from the inlet coupling should terminate in the following ways.

- (a) In an oil-fired boiler room : about 1 m above the level of the oil burners, with a separate outlet above each burner.
- (b) In an oil storage tank chamber : about 150 mm above the estimated level of the oil should the total contents of the tank(s), when full, be discharged into the chamber.
- (c) In a transformer chamber : at ceiling level. (For earthing see 12.2).

Section six. Components and materials

25. General conformity with standards

Material, appliances and components should fulfil the requirements of the local water undertaking and the fire authority and unless otherwise stipulated by the purchaser should comply with the requirements of the relevant British Standards.

NOTE. It is the practice of some water undertakings to stamp items of equipment following inspection and test.

26. Particular requirements

Particular items should comply with the following requirements.

- (a) Ballvalves - to BS 1212 : Part 1 or Part 2
- (b) Boxes for foam inlets and dry risers - to BS 5041 : Part 5
- (c) Boxes for landing valves for dry risers - to BS 5041 : Part 4
- (d) Colour identification - to BS 1710
- (e) Fire hydrants (underground) - to BS 750
- (f) Fire hydrants (pillar) should be made of suitable corrosion protected and sufficiently robust material. Their working parts should be of gunmetal, to BS 1400 or other suitable material.
- (g) Hose for fire-fighting purposes - to BS 3169

(h) Hose reel for fixed installations -	to BS 5274 (in course of preparation)
(i) Hydrant indicator plates -	to BS 3251
(j) Inlet breeching for dry risers -	to BS 5041 : Part 3
(k) Isolating valves -	to BS 4312
(l) Landing valves (for dry risers) -	to BS 5041 : Part 2
(m) Landing valves (for wet risers) -	to BS 5041 : Part 1
(o) Pipe for screwing -	to BS 1387
(p) Pipe fittings -	to BS 1740
(q) Pipe and valve flanges -	to BS 10 or 4504
(r) Pipe threads -	to BS 21
(s) Sluice valves -	to BS 1218
(t) Starting switches (automatic) -	to BS 587

Section seven. Installation

27. Work on site

27.1 Adequate provision should be made by the responsible contractor to protect materials and components on site from loss, deterioration or damage.

27.2 Unloading, stacking and storage should be carried out with care to prevent damage to pipes and pipe threads, hydrants, fittings, couplings and other components used in the system.

27.3 Pipes should be securely anchored before any pressure or flow tests are carried out.

28. Protection of buildings under construction

28.1 In order that a fire occurring during the construction of a building can be dealt with effectively, especially in high or extensive buildings where large quantities of combustible materials may be stored, mains as indicated in **28.2** should be in an operational condition as soon as any floor of the building reaches 18 m above fire brigade access level. These mains should be extended progressively as work on the building proceeds to provide fire-fighting facilities at all stages of construction.

28.2 Mains should be:

- (a) for buildings planned not to exceed 60 m height, dry rising mains.
- (b) for buildings planned to exceed 60 m height, either wet rising mains or a wet main installation initially available for use as a dry rising main. In the latter case the system should be complete with an inlet breeching complying with the requirements of BS 5041 : Part 3 once the construction reaches 18 m, and should be extended progressively until a height of over 60 m has been reached when the dry rising main should be converted to a wet rising main.

28.3 It is important that, from the time that the wet rising main is first connected to the water supply the running pressure at each hydrant does not exceed 5 bar*. If this is impracticable for any special reason, a notice should be attached to each landing valve to read 'HIGH PRESSURE MAIN – OPEN VALVE SLIGHTLY UNTIL SUFFICIENT PRESSURE IS OBTAINED'. These notices should remain

on the landing valves until the pressure on the outlets is reduced to 5 bar.

NOTE. Clause 28 introduces a number of new considerations to be taken into account by contractors and others during tendering and planning. To assist those concerned, appendix B includes advice on some of the points to be considered during these stages.

29. Temporary notices

Where reliance is being placed on the operation of fire-fighting systems or appliances during the construction period, temporary notices (to the satisfaction of the fire authority) giving essential information for their protection from damage and for their efficient operation should be set up and remain until the installation becomes fully operative. (See 5.3, 8.2, 19.3 and 40.2.)

Section eight. Initial inspections and acceptance tests

30. Private underground fire hydrants

30.1 Inspection of and, where practicable, a wet test of private under-ground fire hydrants should be made in conjunction with the fire authority and the owner or occupier of the premises or his representative. Where such hydrants are supplied from mains, arrangements should also be made with the water undertaking before tests are carried out.

30.2 During these inspections and tests the condition of the following should be checked and noted for remedial action if necessary:

- (a) pits;
- (b) frames;
- (c) covers;
- (d) surface paving round edges of frames;

In addition the following should be checked:

- (e) depth of outlet below the frame (see 5.3 and figures 1 and 2);
- (f) method of indication by means of hydrant indicator plate or sticker.

30.3 The test should include flushing out the outlet and checking the outlet connection. The flow and pressure at the outlet should also be measured and noted.

30.4 On completion of the test, the operation of the frost valve (where fitted) should be checked, and the pit should be left empty and clean.

31. Test on dry rising mains

31.1 Notification to interested parties. No test shall be carried out without prior notification to the interested parties (i.e. water undertakings, owners or occupiers of the buildings, and a representative of the installers), and regard should be taken of the possibility of cancellation at short notice when adverse weather or drought conditions may be encountered.

31.2 Joint inspection. If it is the fire brigade's responsibility or wish to carry out the test, then its representative, on arrival at the premises, should make contact with a suitable representative of those responsible for the site.

*1 bar = 10⁵ N/m² = 100 kPa

Both these representatives should then carry out in company a physical check of the installation. The inspection should verify that earthing requirements (see 12.1) have been carried out satisfactorily or certified by the electrical contractor.

31.3 Static pressure test

31.3.1 On being satisfied that the system is in order, water should be allowed to flow through it discharging via the topmost outlet to flush out any debris that may be present. This procedure is of particular importance at acceptance tests when quantities of foreign matter may be lodged in the pipework.

31.3.2 The system should then be completely charged with water to a pressure of 10 bar* measured at the inlet for a period of at least 15 min. During this period, an inspection of the system should be made to check that no leakage of water is taking place at any of the joints or landing valves.

31.4 Flow test

31.4.1 After the test in accordance with 31.3 is completed, a flow test should be carried out if this is considered to be necessary.

31.4.2 For this test, water should be passed through the system under pressure and the flow gauge readings recorded. Inability to sustain an effective fire-fighting jet from the topmost outlet, or any undue pressure loss in the rising main (after allowing for the height involved) should be investigated.

31.5 Remedial action and retesting. If as a result of these tests any defects are found, these should be remedied as necessary and a retest of the system should be carried out.

31.6 Putting into operational readiness

31.6.1 When the pressure has been released at the pumping appliance the coupling to the rising main inlet should be disconnected and the action of the non-return valves checked.

31.6.2 The system should then be drained and left ready for use.

32. Tests on wet rising mains

32.1 Desirability of 'built-in' test facilities. Consideration should be given to incorporating 'built-in' test facilities for each wet rising main owing to the difficulties that may otherwise be experienced in disposing of water and the risk of burst hose and consequent water damage.

32.2 Procedure for test. The procedure is basically the same as that for dry rising mains given in clause 31, and in all wet rising mains both the static pressure test and the flow test should be carried out.

32.3 Test of standby pumps. Particular attention should be paid to the ability of any pump which may be required for standby to operate satisfactorily on failure of the duty pump, and this should be tested.

33. Hose reel tests

33.1 Flushing out. Before any water is introduced into the hose reel the supply to it should be thoroughly flushed out to ensure that no harmful matter is passed into the reel. This is particularly important for automatic hose reels. After flushing out, the tubing should be run out and the water turned on to establish that the assembly is fully operational.

33.2 Procedure (direct mains supply). The two most highly situated and remote reels should be discharged simultaneously, one being led to waste and the other directed into a suitable receptacle to ascertain that the flow rate specified in 9.3.1 is achieved. For the purpose of this test it will be necessary to provide a receptacle of a suitable capacity.

33.3 Procedure (boosted supplies). The two most highly situated and remote reels should be discharged simultaneously, until the duty pump cuts in automatically. Thereafter, with both reels still in operation, the discharge rate of one of them should be measured as in 33.2

The test should be repeated. This time a simulated mechanical or electrical failure of the duty pump should be arranged, and the ability of the standby pump to come into service automatically and to maintain the required outputs should be tested.

33.4 Putting into operational readiness

33.4.1 When the tests in 33.2 and 33.3 have been satisfactorily completed, the system should be restored to its normal operating state. Reels should never be left under pressure and, where practicable, hose should be drained prior to being returned to the drum.

33.4.2 Hose should be restowed on the drums, particular attention being paid to automatic hose reels to ensure that the automatic valve is fully closed when the hose has been restowed. Where an isolation valve has been incorporated this should be closed on completion of stowage, and the nozzle interlock, where fitted, should be completed.

33.4.3 Where it is the practice of water undertakings to seal the inlet valve to the reel, the undertaking concerned should be notified of the test.

34. Foam inlet acceptance inspection

34.1 The layout of all foam inlets should be checked to ascertain that they conform to the approved layout plan.

34.2 Any inlet coupling should also be checked to ensure correct functioning, and to verify that earthing requirements (see 12.1) have been carried out satisfactorily or certified by the electrical contractor.

35. Indemnities

Before testing any system or hose reel a signed indemnity should be sought from the person at that time responsible for the work site or premises. This may be required by the fire authority in respect of liability for damage caused to persons or property arising out of, or in connection with, any test.

*1 bar = 10^5 N/m² = 100 kPa

36. Test records

A permanent record of all initial inspections and acceptance tests should be kept by the owner or occupier. This should record:

- (a) date and time for inspection or test;
- (b) person carrying out the test;
- (c) test results noted;
- (d) any external factors significantly affecting the results (e.g. weather conditions);
- (e) follow up action required;
- (f) work carried out as a result of (e) with date and result of retest.

Section nine. Maintenance of systems and rectification of defects

37. Fire hydrants

37.1 Arrangements should be made by the owners or the occupiers to ensure that, at least once a year, maintenance is carried out on all private fire hydrants by a competent person. In most cases these arrangements, subject to suitable financial provisions, can be made with the local water undertaking or the fire authority. The former may also be prepared to carry out any necessary repair work.

37.2 Periodical inspections of the vicinity of all hydrants should also be made to ensure that there are no obstructions impeding accessibility and that hydrant indicator plates are in position.

37.3 Periodic inspection should be made to ensure that all isolating valves for systems are kept locked in an 'open' position. Also flow and pressure should be checked to ensure that supplies have not deteriorated.

38. Rising mains

38.1 Competence of maintenance personnel. The services of a competent person should be obtained to carry out maintenance and repairs.

38.2 Dry rising mains

38.2.1 Inlets, landing valves, drain valves, door hinges and locking arrangements to the inlet and landing valve boxes should be inspected every six months. Special attention should be given to all valves, spindles, glands and washers to ensure that they are in satisfactory condition, so that all equipment is ready for immediate use.

38.2.2 In addition, it is recommended that wet tests be carried out annually when the main can be checked for leaks.

38.3 Wet rising mains. Maintenance of wet rising mains involves additional checks from those mentioned in **38.2.1**. These additional checks are:

- (a) check on the cleanliness of storage tanks;
- (b) thorough check of the booster pumps and their associated mechanical and electrical equipment.

38.4 Removal of valve assemblies for replacement. Where outlets on either dry or wet rising mains are found to be

defective and no replacement is immediately available, the whole valve assembly should be removed from the main and be replaced with a blanking off plate or plug in order that the system remains operative. (See **40.2**.)

39. Hose reels

39.1 Hose reels should be subjected to regular inspection to ensure that the inlet valve, the automatic on/off valve (if any), glands, tubing and shut-off nozzle are sound and free from leaks, and also to ensure that the outlet of the nozzle is not choked.

39.2 Some nozzles, in addition to giving a jet stream, are also capable of producing a cone spray. In these cases correct functioning in each role should be checked.

39.3 If booster pumps have been installed (see **18.2**) these and their associated mechanical and electrical equipment should also be checked.

39.4 Once a year the hose should be completely run out and subjected to operational water pressure to ensure that the hose is in good condition and that all couplings are water tight. A flow test should be carried out to ensure that a discharge of at least 0.5 litre/s (30 litres/min) is achieved. If it is not possible to test every hose reel, at least the highest reel on each rising main should be tested.

40. Rectification of defects

40.1 It is essential that all defects are rectified in the shortest possible time, to ensure that the fixed fire-fighting equipment is restored to a satisfactory condition in as short a time as possible.

40.2 Where, due to unforeseen difficulties it is necessary to leave an installation not available for use, the fire brigade should be informed immediately in order that alternative arrangements may be made to cover this deficiency should the need arise. In addition a suitable notice to indicate that the installation is not available for use should be placed in a prominent position. In the case of dry risers or foam inlets the notice should be in the inlet box (see **11.2**).

40.3 When the installation is reinstated, the fire brigade should again be informed so that any alternative arrangements may be cancelled and, if considered necessary, an inspection and test of the repaired installation may be carried out.

41. Hose reel accessibility

41.1 It is essential that the hose reels remain unobstructed and that they should be available for use at all times.

41.2 In buildings that have large open floor areas such as warehouses, the stacking arrangements should provide for unobstructed access to the hose reel. It may also be considered necessary to provide guard rails around the hose reel position to prevent stacking taking place immediately adjacent, care being taken that the guard rails do not obstruct the operation of the hose.

41.3 Where stacking is taking place notices indicating the hose reel positions should be sited at high level. These notices could be situated over the main avenues, subject to directional arrows being provided.

Appendix A

Recommendations for protecting installed equipment from theft and vandalism

(see 7.1.3)

A.1 Introduction. Equipment stolen or damaged may be expensive to replace, but it is even more important to recognize that the effect of the lack of even a small part of any fire fighting installation may seriously delay the attack on a fire and in consequence cause unnecessary loss of life and damage to property. In any situation where installed equipment is at risk from thieves and vandals special measures to protect all parts of the installation are essential, provided that these measures do not inhibit the primary purpose for which the equipment is installed. Precautions of any kind in these circumstances are however of little use unless the installation is kept under adequate surveillance.

Measures designed to discourage persons from removing or damaging equipment are given below.

A.2 Reduced attractiveness. Materials which have a high scrap value may be attractive targets for thieves. Components from materials of lower value can be considered when their use is permitted by a British Standard, but in those cases in which there is no standard the local fire authority should be consulted.

Until the outcome of field trials for plastics hydrant outlets are known and sufficient experience has been gained from their use plastics for these components should not be specified.

A.3 Making theft more difficult

A.3.1 All exposed screw threads or heads of nuts should be spot welded.

A.3.2 Where it is permitted to choose between providing a panel in the door of a box and providing a panel of breakable material, the latter design, being somewhat less obviously vulnerable, may be adopted.

NOTE. Some fire authorities permit the use of solid fronted boxes secured by hasp, staple and padlock. These may make it more difficult to tamper with the contents of the box but they have not been accepted as complying with the requirements of British Standards.

A.4 Action on discovering theft or damage

A.4.1 As soon as loss or damage is noticed the fire authority, the owners and the police should be informed.

A.4.2 A notice reading 'FIRE MAIN OUT OF ORDER' should be placed in the inlet box of any riser so affected until the fire authority has checked the position and has accepted the main as restored to service. The letters on this notice should preferably be in white and should be at least 50 mm high on a red background (see 40.2).

Appendix B

Matters to be considered relating to the provision of fire fighting installations during building construction

B.1 Introduction. The recommendations given in clause 28 involve measures which have not generally been introduced previously, but which will in future be likely to become more usual. These measures should be taken account of in the tendering and planning stages of a contract, and to assist those concerned in the matter a list of some points which need attention is given below. This list should not by any means be considered exhaustive, and some of the points listed may not be applicable in all circumstances.

B.2 Points for consideration. The following points should be considered.

(a) The contractor/subcontractor responsible for the fire services will need to plan for the risers to be installed as each floor is erected.

(b) Fire authorities may require the system to be tested after each addition to the installation.

(c) Where wet risers are installed, electrical power to operate the pumps will be required, together with an adequate water supply and standby equipment. Earthing of the systems will also have to be complete.

(d) In winter, it will be necessary to provide effective frost protection against water services becoming frozen.

(e) Temporary site electricity supplies may not be considered adequate for fire fighting purposes and the apparatus may need to be connected to permanent electricity supplies. Such permanent supplies would, therefore, need to be installed at a reasonably early stage of construction and all switch gear and cables protected against fire at all times.

(f) The early provision of a permanent electricity supply would involve questions of cost, negotiations with the electricity supply board and arranging appropriate agreements.

(g) It may also be necessary for a lift to be operational for the firemen's use.

(h) Where there are no underground fire hydrants local to site, it will also be necessary to arrange for the fire mains to be brought to a position adjacent to the dry riser position, and also to ensure that there is adequate hard standing and roadways for fire brigade appliances. (See 5.1 and clause 11.)

(i) Where new buildings have long drying out or commissioning periods, and they have oil fired boilers, the foam pipework (see clause 23) will also have to be installed before the boilers are fired.

BSI publications referred to in this standard

This standard makes reference to the following British Standards:

BS 10	Flanges and bolting for pipes, valves and fittings	BS 4504	Flanges and bolting for pipes valves and fittings. Metric series
BS 21	Pipe threads for tubes and fittings where pressure-tight joints are made on the threads	BS 5041	Fire hydrant systems equipment
BS 336	Fire hose couplings and ancillary equipment	Part 1	Landing valves for wet risers
BS 587	Motor starters and controllers	Part 2	Landing valves for dry risers
BS 750	Underground fire hydrants and dimensions of surface box openings	Part 3	Inlet breeching for dry risers
BS 1212	Ballvalves (excluding floats)	Part 4	Boxes for landing valves for dry risers
	Part 1 Piston type	Part 5	Boxes for foam inlets and dry risers (formerly BS 3980)
	Part 2 Diaphragm type (brass body)	BS 5274 *	Fire hose reels for fixed installations
BS 1218	Sluice valves for waterworks purposes	BS 5499	Fire safety signs, notices and graphic symbols
BS 1387	Steel tubes and tubulars suitable for screwing to BS 21 pipe threads	Part 1	Specification for fire safety signs
BS 1400	Copper alloy ingot and copper and copper alloy castings	CP 3	Code of basic data for design of buildings
BS 1710	Identification of pipelines	Chapter IV	Precautions against fire
BS 1740	Wrought steel pipe fittings (screwed BSP thread)	CP 99	Frost precautions for water services
BS 3169	Rubber reel hose for fire-fighting purposes	CP 402	Fire fighting installations and equipment
BS 3251	Hydrant indicator plates	CP 402.201	Sprinkler systems
BS 3763	The International System of units (SI)	CP 1013	Earthing
BS 4312	Flanged steel screw-down stop valves and stop check valves for general purposes	PD 6444	Recommendations for the co-ordination of dimensions in building basic spaces for engineering services and draining components and assemblies
BS 4422	Glossary of terms associated with fire	Part 3	(Functional Group 4)
	Part 4 Fire protection equipment		

*In course of preparation

This British Standard, having been prepared by a committee convened by the Codes of Practice Committee for the Building Industry was published under the authority of the Executive Board on 27 February 1976.

© British Standards Institution, 1976

First published as CP 402.101 April 1932

First revision as BS 5306 : Part 1 February 1976

ISBN: 0 580 08857 X

The following BSI references relate to the work on this standard:
Committee reference BLCP/43 Draft for comment 72/11960 DC

British Standards Institution. Incorporated by Royal Charter, BSI is the independent national body for the preparation of British Standards. It is the UK member of the International Organization for Standardization and UK sponsor of the British National Committee of the International Electrotechnical Commission.

In addition to the preparation and promulgation of standards, BSI offers specialist services including the provision of information through the BSI Library and Standardline Database; Technical Help to Exporters; and other services. Advice can be obtained from the Enquiry Section, BSI, Milton Keynes MK14 6LE, telephone 0908 221166, telex 825777.

Copyright. Users of British Standards are reminded that copyright subsists in all BSI publications. No part of this publication may be reproduced in any form without the prior permission in writing of

BSI. This does not preclude the free use, in the course of implementing the standard, of necessary details such as symbols and size, type or grade designations. Enquiries should be addressed to the Publications Manager, BSI, Linford Wood, Milton Keynes MK14 6LE. The number for telephone enquiries is 0908 220022 and for telex 825777.

Contract requirements. A British Standard does not purport to include all the necessary provisions of a contract. Users of British Standards are responsible for their correct application.

Revision of British Standards. British Standards are revised, when necessary, by the issue either of amendments or of revised editions. **It is important that users of British Standards should ascertain that they are in possession of the latest amendments or editions.**

Automatic updating service. BSI provides an economic, individual and automatic standards updating service called **PLUS**. Details are available from BSI Enquiry Section at Milton Keynes, telephone 0908 221166, telex 825777.

Information on all BSI publications is in the *BSI Catalogue*, supplemented each month by *BSI News* which is available to subscribing members of BSI and gives details of new publications, revisions, amendments and withdrawn standards. Any person who, when making use of a British Standard, encounters an inaccuracy or ambiguity, is requested to notify BSI without delay in order that the matter may be investigated and appropriate action taken.

Code drafting committee BLCP/43

Fire extinguishing installations and equipment in building

Mr J W Mills (Chairman)
Mr L Heavyside

British Fire Protection Systems Association

Mr H Sanders¹
Mr T A Andrews

*British Railways Board
Chief and Assistant Chief Fire Officers' Association
Confederation of British Industry*

Mr R Hirst
Fire Advisor to
HM Factory Inspectorate
Mr M A Hall²
Mr S E Cook³
Mr P V Pearson⁴
Mr P Nash

*Department of Employment
Department of the Environment
Department of the Environment,
Joint Fire Research Organisation
and Fire Offices' Committee
Department of Trade and Industry
(Marine Division)*

Mr J E Lodge⁵

Mr A G Clarke⁶
Mr D F Rose⁷
Dr J H Dyer⁷
Mr R Mortimer⁸
Mr M J Osborne
Mr H Unger⁹
Mr D H R Willy¹⁰
Mr G C Ackroyd
Chief Technical Officer
Mr R J H Miller¹¹
Mr R Peskett¹²
Mr C H Gibbs
Mr R M Simpson

Fire Extinguishing Trades Association

*Fire Offices' Committee
Fire Protection Association
Greater London Council –
London Fire Brigade
Home Office*

Mr G Nash
The secretary
Mr T E Robinson¹³
Mr G K Lockyer¹⁴
Mr C P Barber¹⁵
Mr F P Rendell¹⁶
Mr J C Bishop
Mr N S Marsh
Mr K R Shutt
Mr D A Wilkinson
Mr F C Clarke

Institute of Petroleum

Institution of Fire Engineers

London Transport Executive

Ministry of Defence

*Coopted
BSI*

- 1) Resigned October 1973
- 2) Resigned February 1973
- 3) From February 1973 until August 1974
- 4) Nominated August 1974
- 5) Resigned June 1974
- 6) From January 1973 to June 1973
- 7) Nominated June 1973
- 8) Nominated June 1973
- 9) Resigned June 1973
- 10) Resigned January 1973
- 11) Resigned January 1975
- 12) Nominated January 1975
- 13) Resigned November 1974
- 14) Nominated November 1974
- 15) Resigned October 1973
- 16) Nominated October 1973
- 17) Nominated February 1972

Amendments issued since publication

Amd. No.	Date of issue	Text affected
4649	August 1984	Indicated by a line in the margin